

## Vákuumkorong

- Két típus: lapos vagy egyredős kivitel.
- Négy féle anyagminőség: Szilikon, EPDM, Természetes gumi, HNBR.
- Átmérő:  $\varnothing 11-53\text{mm}$ .

## Vacuum cups

- Two styles: flat or with 1.5 bellows.
- Four materials: Silicone, EPDM, natural rubber, HNBR.
- Diameters from 11mm to 53mm.

## Anyag kiválasztása

Az utolsó három jelzés utal az anyagra és a színre.

## Material choice

The three final characters in the code identify the material and the color.

Kód  
Code

					S	0	1						E	0	2						R	0	3						H	0	4
Szilikon Silicone								EPDM								Natúrgumi Natural rubber								Non-marking HNBR							

Szín Color	Piros Red	Fekete Black	Zöld Green	Kék Blue
Keménységi fok (Sh.A) Hardness	55	48	53	60
Üzemi hőmérséklet Temperature range	$-70^{\circ} \div +200^{\circ}$	$-40^{\circ} \div +100^{\circ}$	$-40^{\circ} \div +80^{\circ}$	$-25^{\circ} \div +150^{\circ}$
Felhasználási terület Typical applications	Élelmiszer Food	Autóipar Automotive	Papír Paper	Műanyag Plastics

P/G korongátmérőtől függően, két különböző adapter létezik: P és G típus  
According to the cup diameter there are two connections: P type and G type

R A legkisebb görbületi sugár.  
Radius of the smallest grippable ball

V Belső térfogat  
The inner volume

s Összehúzódnás  
Vertical stroke

m Súly  
Weight

F Terhelhetőség -0.6bárnál  
Suction force at -0.6bar

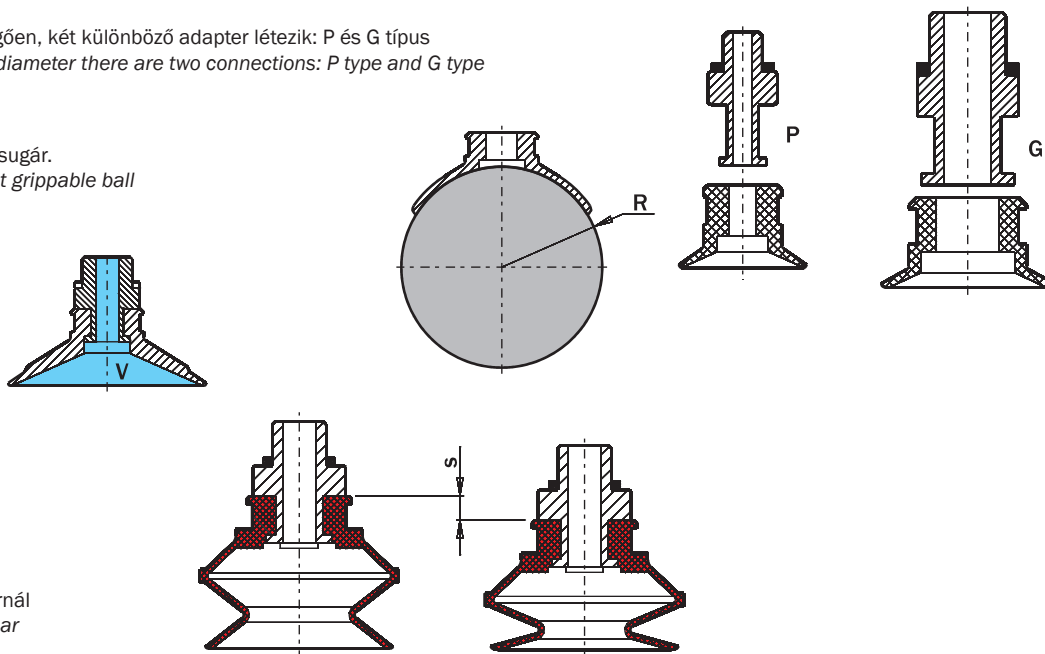

## Lapos vákuumkorong Flat vacuum cups

Kód  
Code

V 0 1

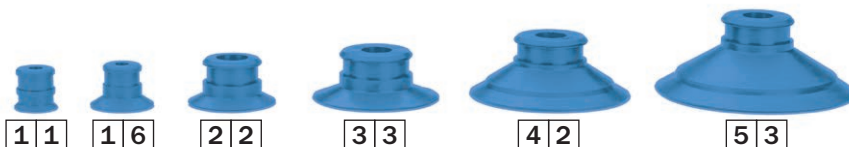
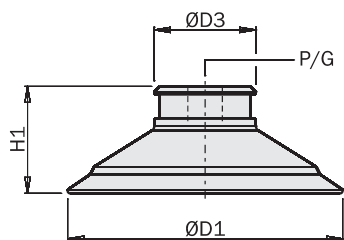

V01	P/G	D1 [mm]	D3 [mm]	H1 [mm]	R [mm]	s [mm]	V [cm <sup>3</sup> ]	m [g]	F [N]
V0111S01									
V0111E02	P	Ø11	Ø10	10	8	0.5	0.2	0.6	2.3
V0111R03									
V0111H04									
V0116S01									
V0116E02	P	Ø16.2	Ø10	10.5	8	1.5	0.3	0.6	5.2
V0116R03									
V0116H04									
V0122S01									
V0122E02	G	Ø22	Ø15	11.5	13	2.5	1.1	1.3	8.6
V0122R03									
V0122H04									
V0133S01									
V0133E02	G	Ø32	Ø19	12.5	20	3.5	1.7	2.7	17
V0133R03									
V0133H04									
V0142S01									
V0142E02	G	Ø41	Ø19	15.5	30	4.5	3.5	4.6	32
V0142R03									
V0142H04									
V0153S01									
V0153E02	G	Ø51.4	Ø19	20	35	6	8	8.6	45
V0153R03									
V0153H04									

## Redős vákuumkorong Bellow vacuum cups

Kód  
Code

V 0 2

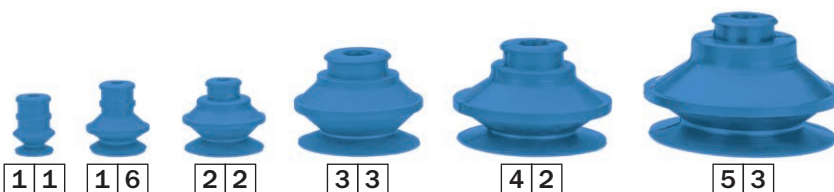
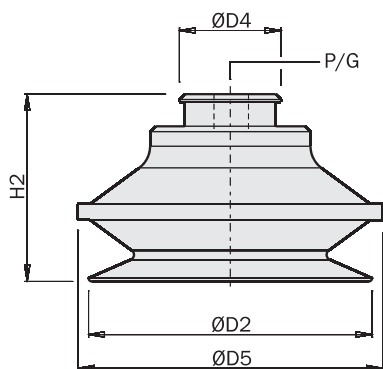

V02	P/G	D2 [mm]	D4 [mm]	D5 [mm]	H2 [mm]	R [mm]	s [mm]	V [cm <sup>3</sup> ]	m [g]	F [N]
V0211S01										
V0211E02	P	Ø11	Ø10	Ø12	15.4	4	4.5	0.4	0.8	0.7
V0211R03										
V0211H04										
V0216S01										
V0216E02	P	Ø15.7	Ø10	Ø17.5	18.8	5	6.5	1	1.3	3
V0216R03										
V0216H04										
V0222S01										
V0222E02	P	Ø22	Ø10	Ø23	19	10	10	2	1.6	5.4
V0222R03										
V0222H04										
V0233S01										
V0233E02	G	Ø34	Ø19	Ø36	26	15	15	10	5.2	17
V0233R03										
V0233H04										
V0242S01										
V0242E02	G	Ø42	Ø19	Ø45	28	20	15	14	8.4	23
V0242R03										
V0242H04										
V0253S01										
V0253E02	G	Ø53	Ø19	Ø57	35	30	15	30	14.4	47
V0253R03										
V0253H04										