

## Pneumatikus Billenő egység megfogó-fejhez, RBT sorozat

- Elfordulás: 90° (1).
- Két állítható végállás ütközővel (2).
- Nagy nyomaték a kilincsműves kialakítás miatt.
- Biztonsági zár (3), kivéve: RBT30
- Mágneses szenzor (opció).

## Pneumatic tilt units for EOATs, series RBT

- 90° rotation (1).
- Two rubber adjustable end strokes (2).
- High lifting torque.
- Safety lock (3), except RBT30.
- Optional magnetic sensors.

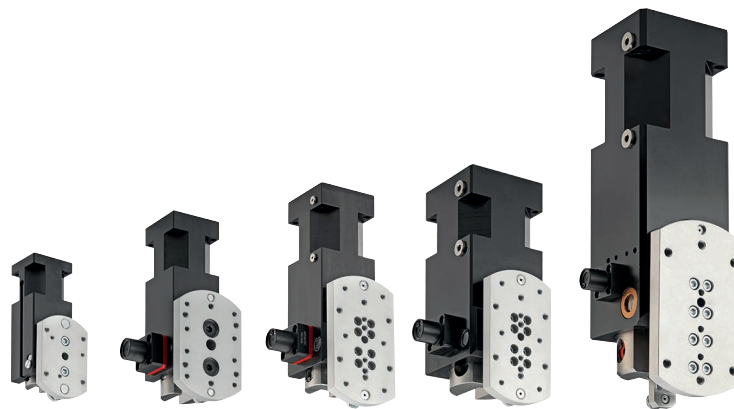
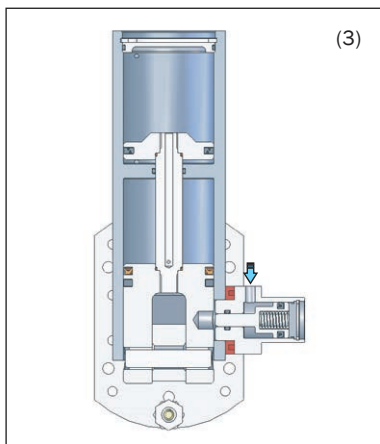
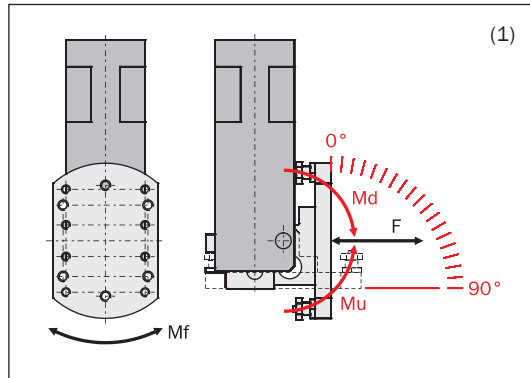
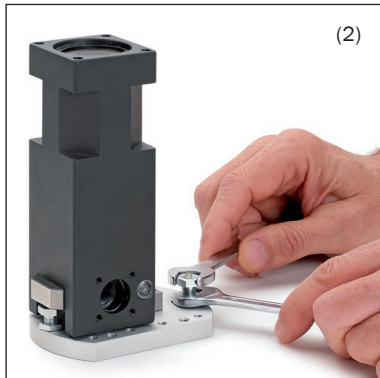

	RBT30	RBT40	RBT50	RBT63	RBT80
Közeg Medium	Szűrt, zsírozott / nem zsírozott levegő nyomás Filtered, lubricated / non lubricated compressed air				
Üzemi nyomás Pressure range	2 ÷ 8 bar				
Reteselő nyomás Unlock pressure	-	> 3.5 bar			
Üzemi hőmérséklet Temperature range	5 ÷ 60 °C.				
Billentési szög Tilt angle	90°				
Végállás beállítása End stroke adjustment	± 2°				
Levegő fogyasztás per ciklus Cycle air consumption	56 cm <sup>3</sup>	142 cm <sup>3</sup>	266 cm <sup>3</sup>	462 cm <sup>3</sup>	983 cm <sup>3</sup>
Nyomaték 6 bárnál (90° → 0°) Lift torque at 6 bar (90° → 0°) (Mu)	> 9 Nm	> 24 Nm	> 45 Nm	> 78 Nm	> 174 Nm
Billentő nyomaték 6 bar-nál (0° → 90°) Drop torque at 6 bar (0° → 90°) (Md)	> 4 Nm	> 11 Nm	> 22 Nm	> 42 Nm	> 84 Nm
Megengedett terhelés Allowed load (F)	50 N	100 N	200 N	300 N	600 N
Megengedett nyomaték Allowed moment (Mf)	3 Nm	7 Nm	12 Nm	30 Nm	75 Nm
Súly Weight	520 g	1050 g	1600 g	2600 g	6500 g

Mérete (mm)  
Dimensions (mm)

RBT30

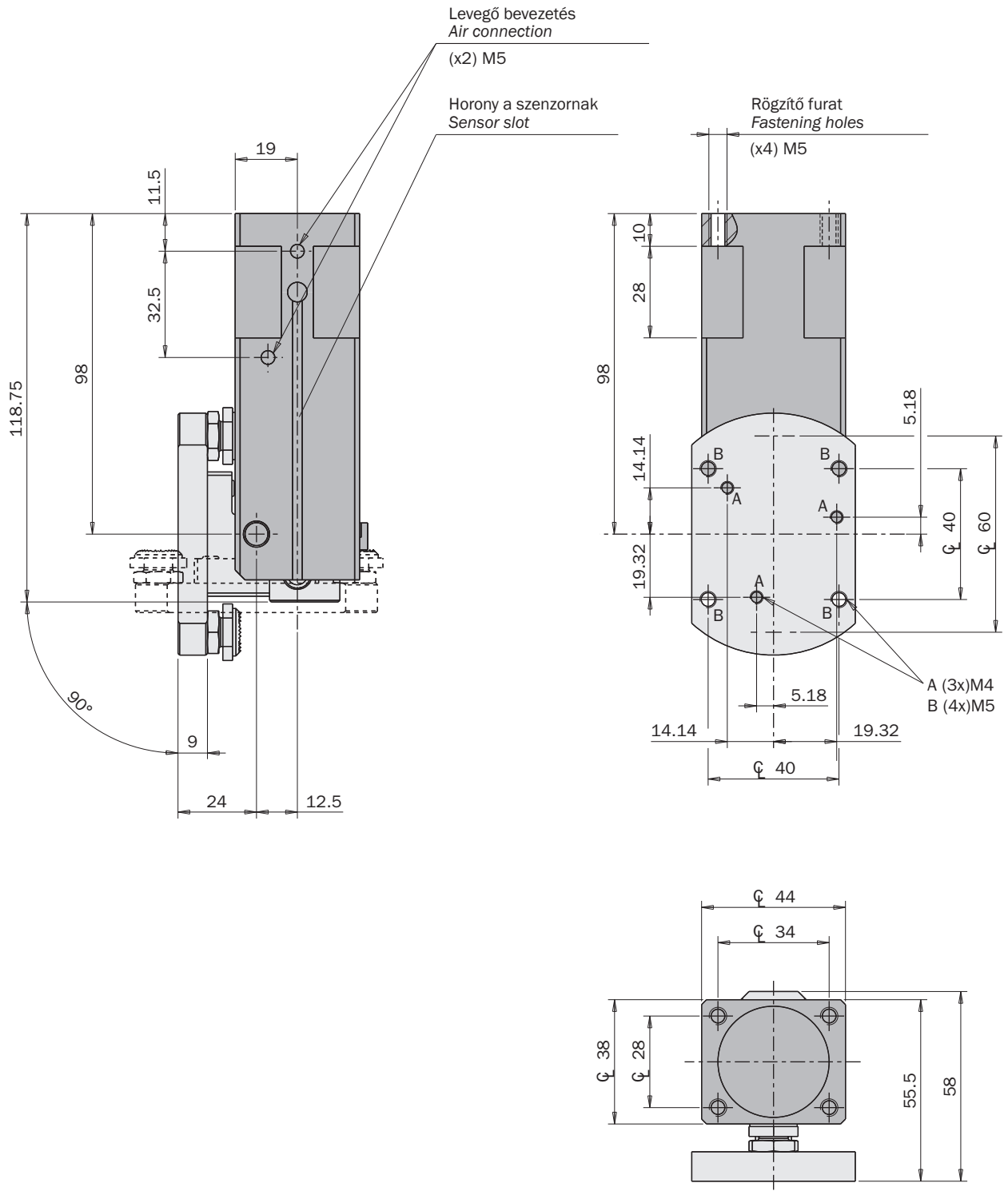

FIRST ANGLE  
PROJECTION

Mérete (mm)  
Dimensions (mm)

RBT40

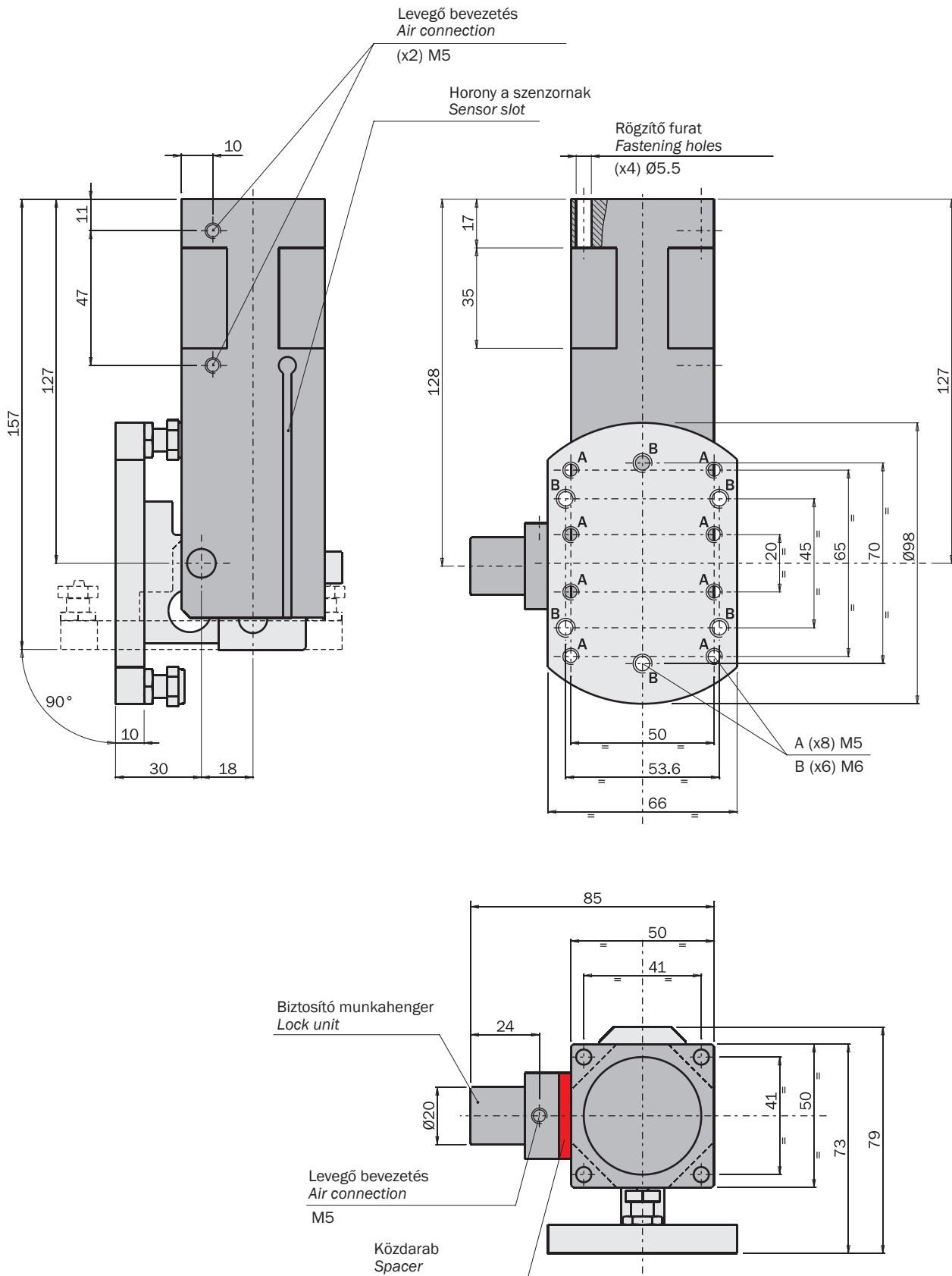

FIRST ANGLE  
PROJECTION

Mérete (mm)  
Dimensions (mm)

RBT50

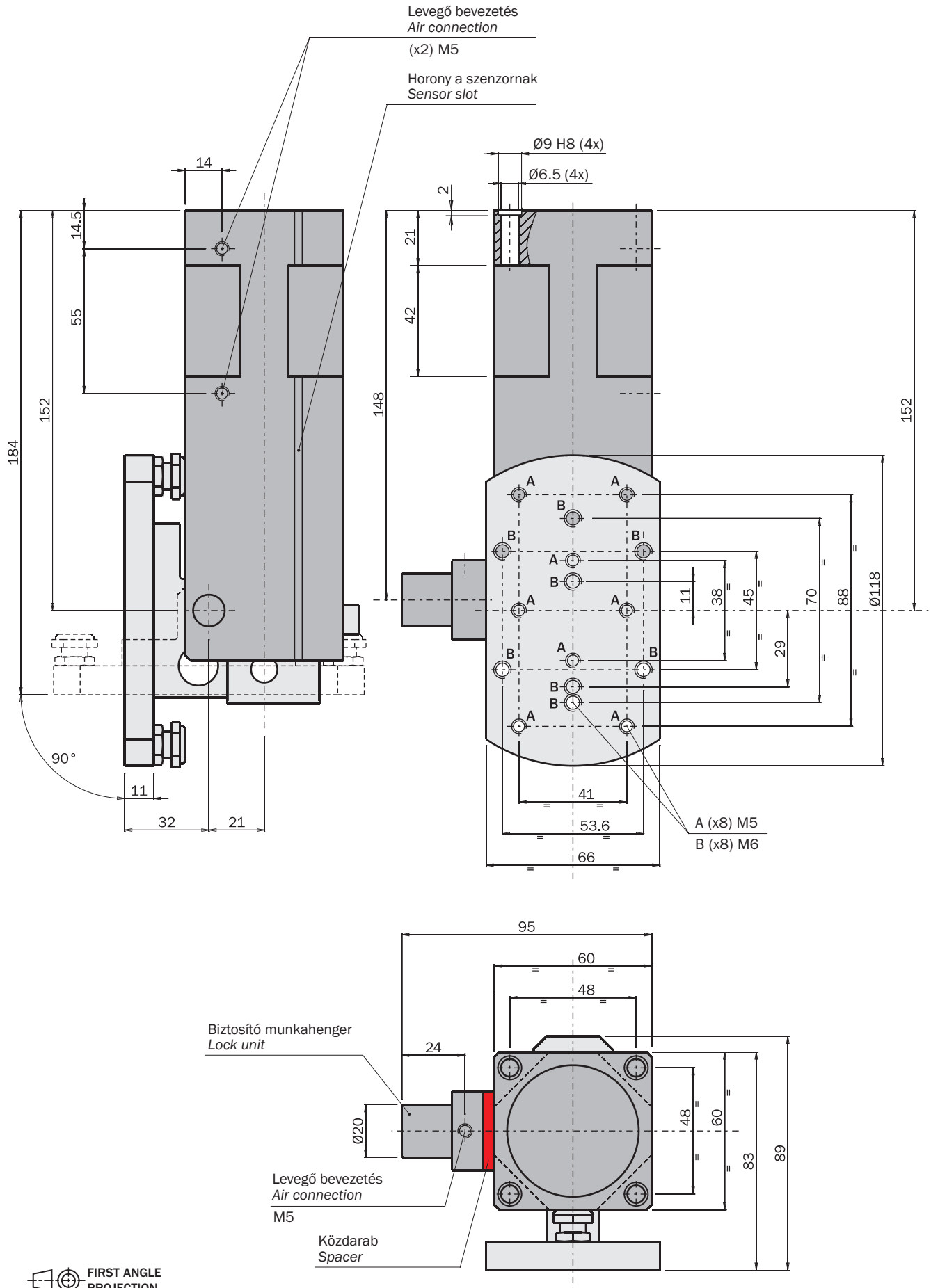

Mérete (mm)  
Dimensions (mm)

RBT63

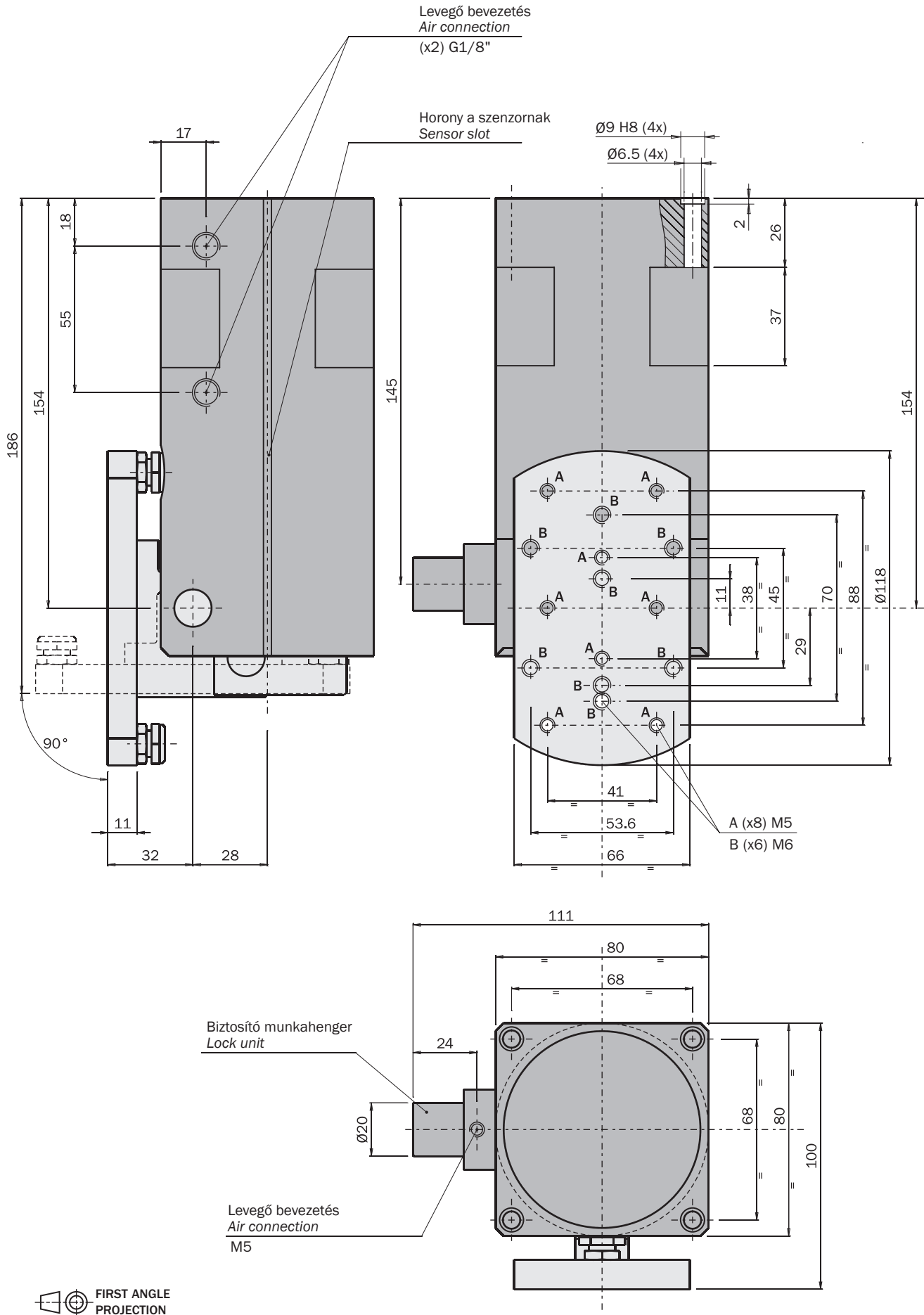

Mérete (mm)  
Dimensions (mm)

RBT80

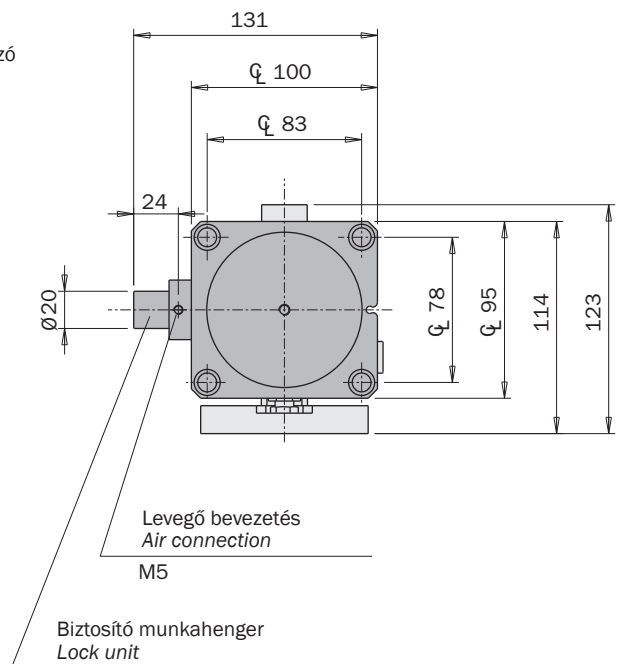
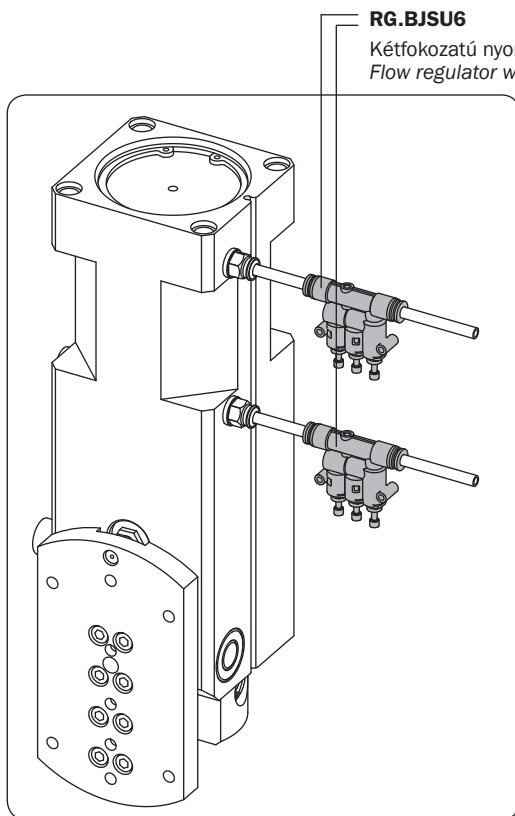
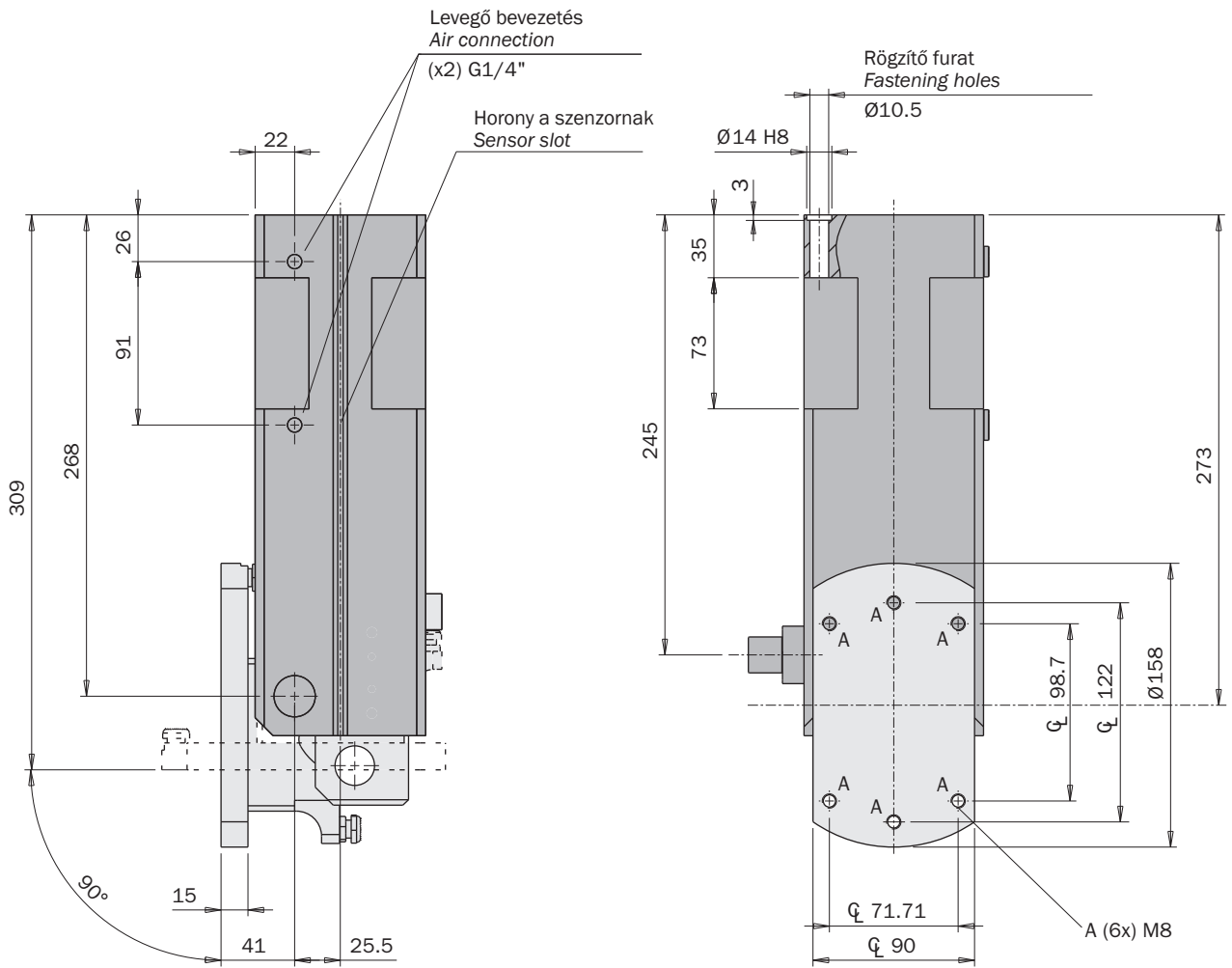

FIRST ANGLE  
PROJECTION