

Pneumatikus, rövidlöketű munkahenger, elfordulásmentes, átmenőfuratos dugattyúszárral

- Kétoldali működtetésű.
- Két méretben érhető el.
- Átmenő levegőcsatlakozás a vákuumkorongnak (4).
- Háromhornyos, golyóval biztosított, elfordulás-mentes szár (1).
- Csatlakoztatható szár, az MFI elemekkel való rögzítéshez (2).
- Hornyok a mágneses szenzoroknak (3).
- FDA-H1 élelmiszer-minőségű kenőzsír.

Short stroke pneumatic cylinder, with non-rotative through hole rod and mounting stud

- Double-effect.
- Two sizes available.
- Through hole for vacuum cup feeding (4).
- Three grooves with balls for non-rotative rod (1).
- Clampable stud for mounting by MFI products (2).
- Optional magnetic sensors (3).
- FDA-H1 food-grade grease.

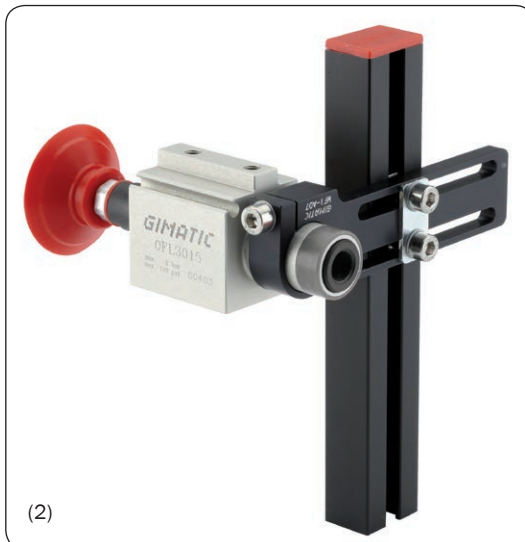
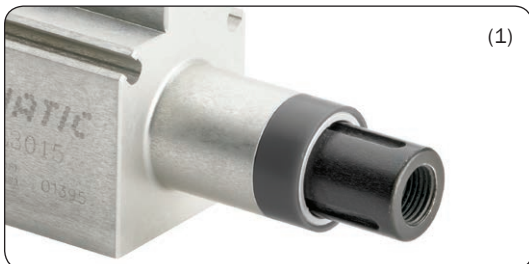

	OFL2010	OFL3015	OFL3030
Közeg Medium	Szűrt, zsírozott / nem zsírozott levegő nyomás Filtered, lubricated / non lubricated compressed air		
Üzemi nyomás Pressure range	2 ÷ 8 bar		
Üzemi hőmérséklet Temperature range	5° ÷ 60 °C.		
Emelkedés Stroke	10 mm	15 mm	30 mm
Furat Piston bore	20 mm	30 mm	30 mm
Záró / nyitóerő 6 barmál Closing / opening force at 6 bar	130 N	300 N	300 N
Levegő fogyasztás per ciklus Cycle air consumption	4.7 cm ³	16 cm ³	32 cm ³
Minimum működtetési idő Minimum actuating time	0.02 s	0.06 s	0.15 s
Súly Weight	60 g	110 g	140 g

Mérete (mm)
Dimensions (mm)

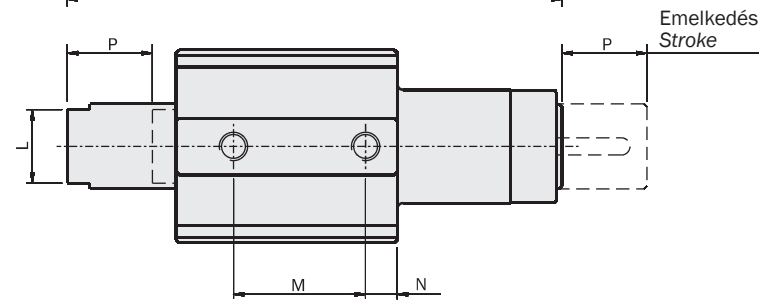
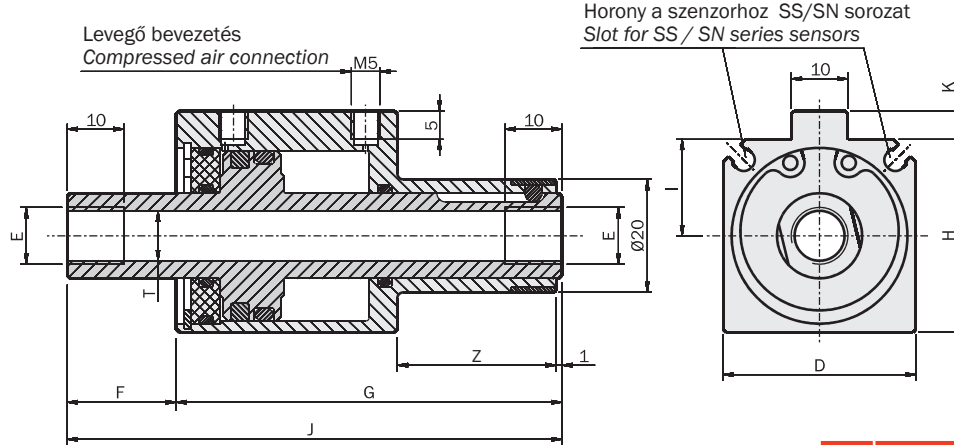
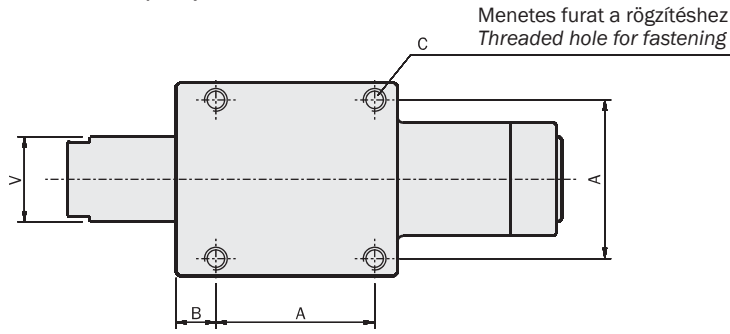

	OFL2010	OFL3015	OFL3030
A	19	28	28
B	9	7	7
C	M3x4	M4x6	M4x6
D	24	34	34
E	M5	G1/8"	G1/8"
F	14.2	19.2	34.2
G	59	68	91
H	25	34	34
I	13	17	17
J	74.2	87.2	125.2
K	4	5	5
L	8	13	13
M	16	23.3	38.3
N	5	5.6	5.6
P	10	15	30
T	Ø4.2	Ø8.8	Ø8.8
V	Ø10	Ø15	Ø15
Z	28	28	36

Alkalmazási példa
Application examples

