

Önbeálló pneumatikus Angusz szögmegefogó, két pófával, DA sorozat

- Egyoldali működtetésű, rugós nyitással.
- Különböző tartozékok a rögzítéshez (1).
- Acél pófákkal.
- Műanyag-acél-alumínium kompozit burkolat (2).
- FDA-H1 élelmiszer-minőségű kenőzsír.

2-jaw self-centering angular pneumatic sprue gripper, series DA

- Single acting with spring opening.
- Several mounting accessories (1).
- Steel jaws.
- Plastic-steel-aluminium composite body (2).
- FDA-H1 food-grade grease.

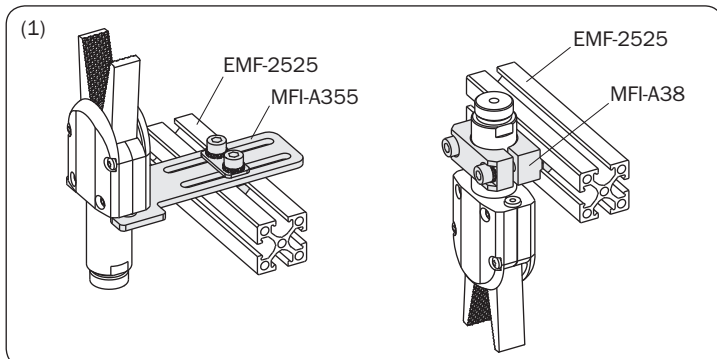

	DA20-16R	DA20-16P	DA20-16E	DA20-16K	DA20-16M	DA20-16W	DA20-16L	DA20-16B	DA20-16T
Közeg Medium	Szűrt, zsírozott / nem zsírozott levegő nyomás Filtered, lubricated / non lubricated compressed air								
Üzemi nyomás Pressure range	2.5 ÷ 8 bar								
Üzemi hőmérséklet Temperature range	5 ÷ 60 °C.								
Emelkedés Stroke	2 x 15°								
Nyomaték per fogópár 6bárnál, zárodó Closing torque at 6 bar each jaw	300 Ncm								
Össz nyomaték 6 bárnál, zárodó Total closing torque at 6 bar	600 Ncm								
Nyomaték per fogópárnál, 0 bárnál, nyitodó Opening torque at 0 bar each jaw	20 Ncm								
Össz znyomaték 0 bárnál, nyitodó Total opening torque at 0 bar	40 Ncm								
Max. Frekvencia állandó üzemben Maximum working frequency	2 Hz								
Levegő fogyasztás per ciklus Cycle air consumption	3.6 cm ³								
Záródó Closing time	0.02 s								
Súly Weight	155 g	150 g	155 g	155 g	160 g	160 g	155 g	199 g	164 g

Mérete (mm)
Dimensions (mm)

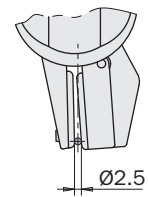
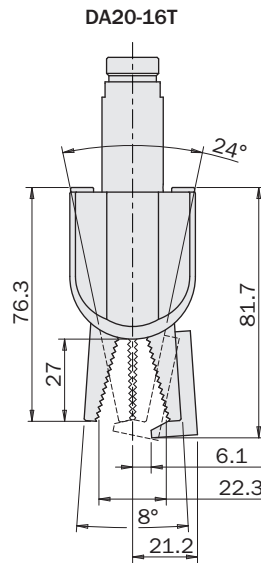
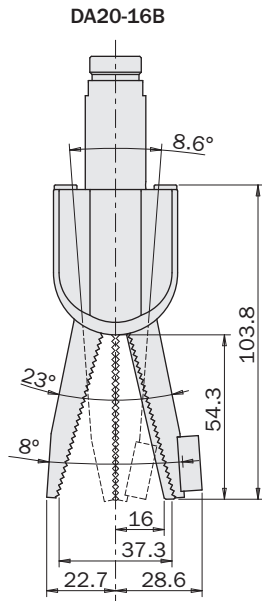
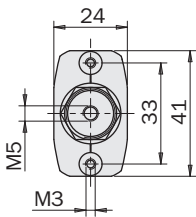
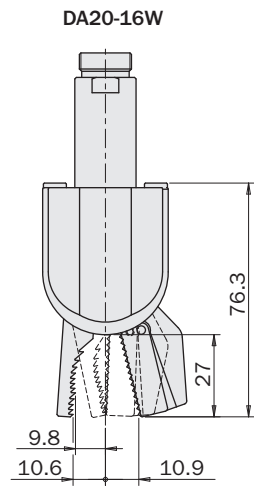
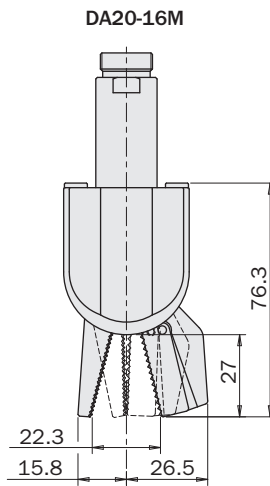
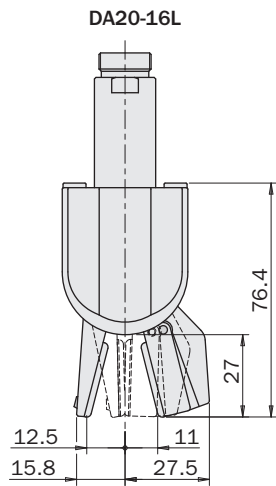
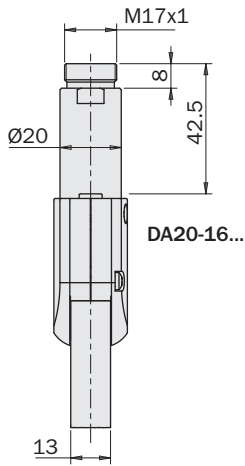
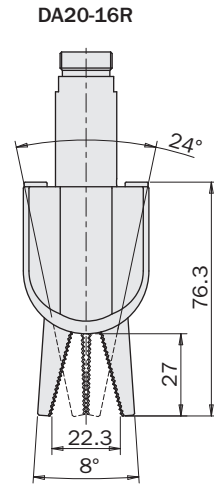
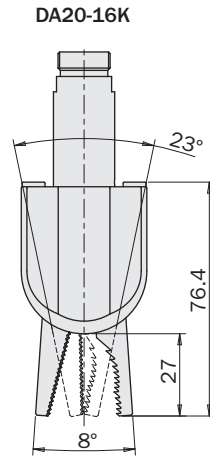
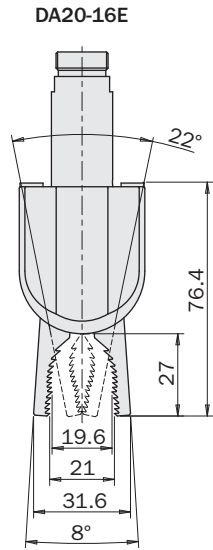
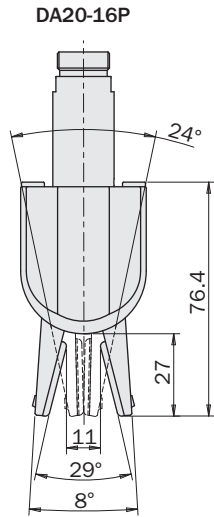

Minimális fogási szélesség
Minimum detectable diameter

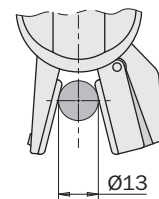

Maximális fogási szélesség
Maximum detectable diameter

